

MILITARY SPECIFICATION

SEMICONDUCTOR DEVICE, TRANSISTOR, PNP, GERMANIUM, POWER

TYPE 2N158

*This specification is mandatory for use by all Departments and Agencies of the Department of Defense.*

1. SCOPE

1.1 Scope. This specification covers the detail requirements for a PNP, germanium, power transistor.

1.2 Physical dimensions. See figure 1.

1.3 Maximum ratings.

$P_T$ <sup>1/</sup>	$V_{CBO}$	$V_{EBO}$	$V_{CES}$	$I_E$	$T_A$
$W$	$V_{dc}$	$V_{dc}$	$V_{dc}$	$A_{dc}$	$^{\circ}C$
17	-60	-30	-60	2	-65 to +100

<sup>1/</sup> Derate linearly 0.283 W/ $^{\circ}C$  for  $T_A > 25^{\circ} C$ .

1.4 Primary electrical characteristics.

Limits	$f_{hfe}$ $V_{CE} = -2 V_{dc}$ $I_C = -0.5 A_{dc}$	$h_{FE}$ $V_{CE} = -2 V_{dc}$ $I_C = -0.5 A_{dc}$	$h_{FE}$ $V_{CE} = -2 V_{dc}$ $I_C = -1.0 A_{dc}$	$V_{CE(sat)}$ $I_B = -150 mA_{dc}$ $I_C = -1.0 A_{dc}$
Min	$kHz$ 4	21	13	$V_{dc}$ ---
Max	---	---	40	-0.75

2. APPLICABLE DOCUMENTS

2.1 The following documents, of the issue in effect on date of invitation for bids or request for proposal, form a part of the specification to the extent specified herein.

SPECIFICATION

MILITARY

MIL-S-19500 - Semiconductor Devices, General Specification for.

STANDARD

MILITARY

MIL-STD-750 - Test Methods for Semiconductor Devices.

(Copies of specifications, standards, drawings, and publications required by suppliers in connection with specific procurement functions should be obtained from the procuring activity or as directed by the contracting officer.)

3. REQUIREMENTS

3.1 **General.** Requirements shall be in accordance with MIL-S-19500, and as specified herein.

3.2 **Abbreviations, symbols, and definitions.** The abbreviations, symbols, and definitions used herein are defined in MIL-S-19500.

3.3 **Design, construction, and physical dimensions.** Transistors shall be of the design, construction, and physical dimensions shown on figure 1.

3.4 **Performance characteristics.** Performance characteristics shall be as specified in tables I, II, and III.

3.5 **Marking.** The following marking specified in MIL-S-19500 may be omitted from the body of the transistor at the option of the manufacturer:

- (a) Country of origin.
- (b) Manufacturer's identification.

4. QUALITY ASSURANCE PROVISIONS

4.1 **Sampling and inspection.** Sampling and inspection shall be in accordance with MIL-S-19500, and as specified herein.

4.2 **Qualification inspection.** Qualification inspection shall consist of the examinations and tests specified in tables I, II, and III.

4.3 **Quality conformance inspection.** Quality conformance inspection shall consist of group A, B, and C inspections.

4.3.1 **Group A inspection.** Group A inspection shall consist of the examinations and tests specified in table I.

4.3.2 **Group B inspection.** Group B inspection shall consist of the examinations and tests specified in table II.

4.3.3 **Group C inspection.** Group C inspection shall consist of the examinations and tests specified in table III. This inspection shall be conducted on the initial lot and thereafter every 6 months during production.

4.3.4 **Group B and group C life-test samples.** Samples that have been subjected to group B, 340-hour life-test, may be continued on test to 1,000 hours in order to satisfy group C life-test requirements. These samples shall be pre-designated, and shall remain subjected to the group C 1,000-hour acceptance evaluation after they have passed the group B, 340-hour acceptance criteria. The cumulative total of failures found during 340-hour test and during the subsequent interval up to 1,000 hours shall be computed for 1,000-hour acceptance criteria (see 4.3.3).

4.4 **Methods of examination and test.** Methods of examination and test shall be as specified in tables I, II, and III.

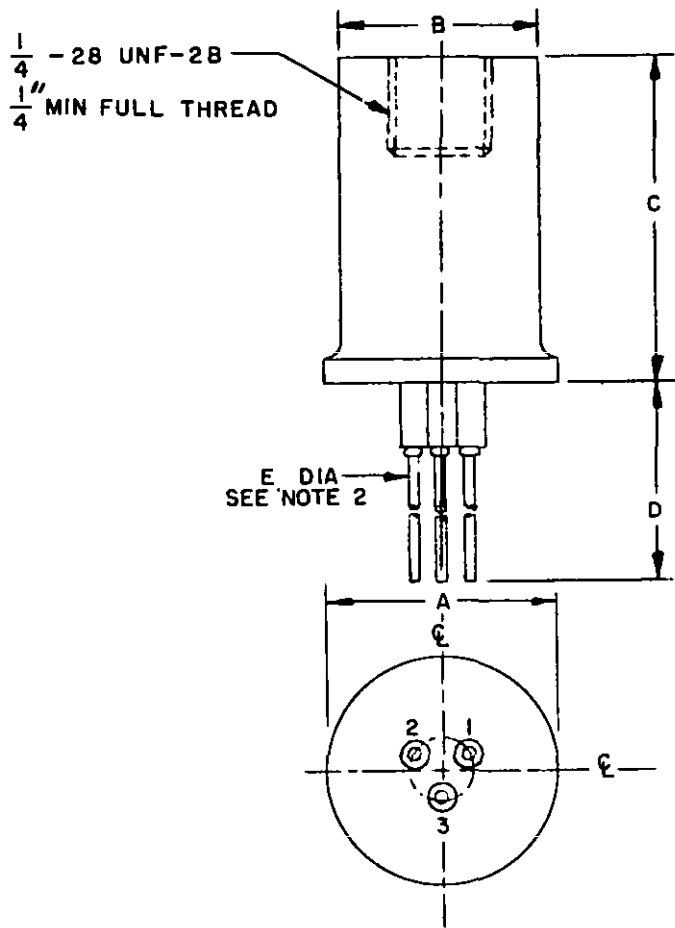

DIMENSIONS				
LTR	INCHES		MILLIMETERS	
	MIN	MAX	MIN	MAX
A	.530	.580	13.46	14.73
B	.415	.525	10.54	13.34
C	.690	.828	17.53	21.03
D	2.000	---	50.80	---
E	.021	.025	.53	.64

## NOTES:

- Metric equivalents (to the nearest .01 mm) are given for general information only and are based upon 1 inch = 25.4 mm.
- Three leads equally spaced.
- The lead arrangement shall be as follows:  
 Lead 1..... Collector..... Black  
 Lead 2..... Base..... White  
 Lead 3..... Emitter..... Red
- The collector shall be electrically connected to the case.

FIGURE 1. Physical dimensions of transistor type 2N158.

TABLE I. Group A inspection

Examination or test	MIL-STD-750		LTPD	Symbol	Limits		Unit
	Method	Details			Min	Max	
<i>Subgroup 1</i>			10				
Visual and mechanical examination	2071			--	--	--	--
<i>Subgroup 2</i>			5				
Breakdown voltage, collector to base	3001	Bias cond D; $I_C = -1.0$ mAde		$BV_{CBO}$	-60	--	Vdc
Breakdown voltage, collector to emitter	3011	Bias cond. D; $I_C = -250$ mAde		$BV_{CEO}$	-30	--	Vdc
Collector to emitter cutoff current	3041	Bias cond C; $V_{CE} = -60$ Vdc		$I_{CES}$	--	-1.5	mAde
Collector to base cutoff current	3036	Bias cond. D; $V_{CB} = -2$ Vdc		$I_{CBO}$	--	-100	$\mu$ Ade
Collector to base cutoff current	3036	Bias cond. D; $V_{CB} = -60$ Vdc		$I_{CBO}$	--	-1.0	mAde
Emitter to base cutoff current	3061	Bias cond. D; $V_{EB} = -30$ Vdc		$I_{EBO}$	--	-0.5	mAde
<i>Subgroup 3</i>			5				
Base emitter voltage (nonsaturated)	3066	Test cond B; $V_{CE} = -2$ Vdc; $I_B = -0.5$ Ade		$V_{BE}$	--	0.85	Vdc
Base emitter voltage (saturated)	3066	Test cond A; $I_B = -150$ mAde; $I_C = -1.0$ Ade		$V_{BE(sat)}$	--	-1.3	Vdc
Collector to emitter voltage (saturated)	3071	$I_B = -150$ mAde; $I_C = -1.0$ Ade		$V_{CE(sat)}$	--	-0.75	Vdc
Forward-current transfer ratio	3076	$V_{CE} = -2$ Vdc; $I_C = -0.5$ Ade		$h_{FE}$	21	--	--
Forward-current transfer ratio	3076	$V_{CE} = -2$ Vdc; $I_C = -1.0$ Ade		$h_{FE}$	13	40	--
<i>Subgroup 4</i>			10				
Small-signal short-circuit forward-current transfer-ratio cutoff frequency	3301	$V_{CE} = -2$ Vdc; $I_C = -0.5$ Ade		$f_{hfc}$	4	--	kHz

TABLE II. Group B inspection.

Examination or test	MIL-STD-750		LTPD	Symbol	Limits		Unit
	Method	Details			Min	Max	
<i>Subgroup 1</i>			10				
Physical dimensions	2066	(See figure 1)		--	--	--	--
<i>Subgroup 2</i>			15				
Solderability	2026			--	--	--	--
Thermal shock (temperature cycling)	1051	Test cond. B, except $T_{max} = +100^\circ\text{C}$		--	--	--	--

TABLE II. Group B inspection - Continued

Examination or test	MIL-STD-750		LTPD	Symbol	Limits		Unit
	Method	Details			Min	Max	
<i>Subgroup 2 - Continued</i>							
Thermal shock (glass strain)	1056	Test cond. A		--	--	--	--
Seal (leak rate)	1071	Test cond. G or H for fine leaks; test cond. A, C, D or F for gross leaks		--	--	$5 \times 10^{-7}$	atm cc/sec
Moisture resistance	1021	Omit initial conditioning		--	--	--	--
End points:							
Collector to base cutoff current	3036	Bias cond. D; $V_{CB} = -60$ Vdc		$I_{CBO}$	--	-1.0	mAdc
Emitter to base cutoff current	3061	Bias cond. D; $V_{EB} = -30$ Vdc		$I_{EBO}$	--	-0.5	mAdc
Forward-current transfer ratio	3076	$V_{CE} = -2$ Vdc; $I_C = -1.0$ Adc		$h_{FE}$	13	40	--
<i>Subgroup 3</i>							
Shock	2016	Nonoperating; 500 G, 1 msec, 5 blows in each orientation: $X_1, Y_1, Y_2,$ and $Z_1$	15	--	--	--	--
Vibration, variable frequency	2056	100 to 1000 Hz; 10 G		--	--	--	--
Constant acceleration	2006	5000 G in each orientation: $X_1, Y_1, Y_2,$ and $Z_1$		--	--	--	--
End points:							
(Same as subgroup 2)							
<i>Subgroup 4</i>							
Terminal strength (lead fatigue)	2036	Test cond. E	20	--	--	--	--
End points:							
Seal (leak-rate)	1071	Test cond. G or H for fine leaks; test cond. A, C, D or F for gross leaks		--	--	$5 \times 10^{-7}$	atm cc/sec
<i>Subgroup 5</i>							
Salt atmosphere (corrosion)	1041		20	--	--	--	--
End points:							
(Same as subgroup 2)							
<i>Subgroup 6</i>							
High-temperature life (nonoperating)	1032	$T_{atg} = +100^\circ$ C; time = 340 hours (see 4.3.4)	7	--	--	--	--

TABLE II. Group B inspection - Continued

Examination or test	MIL-STD-750		LTPD	Symbol	Limits		Unit
	Method	Details			Min	Max	
<i>Subgroup 6 - Continued</i>							
End points:							
Collector to base cutoff current	3036	Bias cond. D; $V_{CB} = -60$ Vdc		$I_{CBO}$	---	-2.0	mAdc
Emitter to base cutoff current	3061	Bias cond. D; $V_{EB} = -30$ Vdc		$I_{EBO}$	---	-1.0	mAdc
Forward-current transfer ratio	3076	$V_{CE} = -2$ Vdc; $I_C = 1.0$ Adc		$h_{FE}$	8	50	---
<i>Subgroup 7</i>							
Steady-state operation life	1027	$T_C = +60^{\circ} \pm 5^{\circ}C$ ; $V_{CB} = -14$ Vdc; $P_T = 7$ W; time = 340 hours (see 4.3.4)	10	---	---	---	---
End points:							
(Same as subgroup 6)							

TABLE III. Group C inspection

Examination or test	MIL-STD-750		LTPD	Symbol	Limits		Unit
	Method	Details			Min	Max	
<i>Subgroup 1</i>							
Thermal resistance	3131		20	$\theta_{J-C}$	---	3.5	$^{\circ}C/W$
<i>Subgroup 2</i>							
High-temperature life (nonoperating)	1031	$T_{stg} = +100^{\circ}C$ (see 4.3.4)	$\lambda=10$	---	---	---	---
End points:							
(Same as subgroup 6 of group B)							
<i>Subgroup 3</i>							
Steady-state operation life	1026	$T_C = +60^{\circ} \pm 5^{\circ}C$ ; $V_{CB} = -14$ Vdc; $P_T = 7$ W (see 4.3.4)	$\lambda=15$	---	---	---	---
End points:							
(Same as subgroup 6 of group B)							

**5. PREPARATION FOR DELIVERY**

5.1 See MIL-S-19500, section 5.

**6. NOTES:**

6.1 Notes. The notes specified in MIL-S-19500 are applicable to this specification.

**Customers:**

Army - EL  
Navy - EC  
Air Force - 85

**Review activities:**

Army - MU, MI  
Navy - SH  
Air Force - 11, 17  
DSA - ES

**User activities:**

Army - SM  
Navy - CG, MC, OS, AS  
Air Force - 13, 15, 19, 70, 80

**Preparing activity:**

Navy - EC

**Agent:**

DSA - ES

(Project 5961-0156)

FOLD

---

DEPARTMENT OF THE NAVY  
NAVAL ELECTRONIC SYSTEMS COMMAND  
WASHINGTON, D. C. 20360

POSTAGE AND FEES PAID  
NAVY DEPARTMENT

OFFICIAL BUSINESS

COMMANDER  
NAVAL ELECTRONIC SYSTEMS COMMAND  
DEFENSE STANDARDIZATION PROGRAM BRANCH  
DEPARTMENT OF THE NAVY  
WASHINGTON, D. C. 20360

---

FOLD



**SPECIFICATION ANALYSIS SHEET**

Form Approved  
Budget Bureau No. 119-R004

INSTRUCTIONS

This sheet is to be filled out by personnel either Government or contractor, involved in the use of the specification in procurement of products for ultimate use by the Department of Defense. This sheet is provided for obtaining information on the use of this specification which will insure that suitable products can be procured with a minimum amount of delay and at the least cost. Comments and the return of this form will be appreciated. Fold on lines on reverse side, staple in corner, and send to preparing activity (as indicated on reverse hereof).

SPECIFICATION

ORGANIZATION (Of submitter)

CITY AND STATE

CONTRACT NO.

QUANTITY OF ITEMS PROCURED

DOLLAR AMOUNT

\$

MATERIAL PROCURED UNDER A

DIRECT GOVERNMENT CONTRACT

SUBCONTRACT

1. HAS ANY PART OF THE SPECIFICATION CREATED PROBLEMS OR REQUIRED INTERPRETATION IN PROCUREMENT USE?  
A. GIVE PARAGRAPH NUMBER AND WORDING.

B. RECOMMENDATIONS FOR CORRECTING THE DEFICIENCIES.

2. COMMENTS ON ANY SPECIFICATION REQUIREMENT CONSIDERED TOO RIGID

3. IS THE SPECIFICATION RESTRICTIVE?

YES

NO IF "YES", IN WHAT WAY?

4. REMARKS (Attach any pertinent data which may be of use in improving this specification. If there are additional papers, attach to form and place both in an envelope addressed to preparing activity)

SUBMITTED BY (Printed or typed name and activity)

DATE